



Specialty Flange & Fitting

Wholesaler of Carbon, Stainless, and Specialty Alloy
Pipe, Valve, & Fitting Products for Over 25 Years

FLANGE PRODUCT CATALOG



BLIND

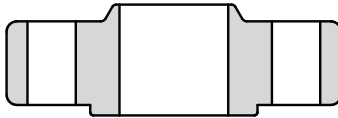

SLIP-ON

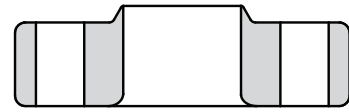

LAP JOINT

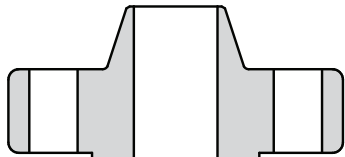

WELD NECK

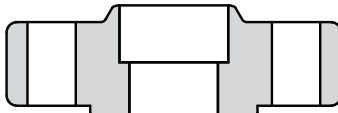

SOCKET WELD

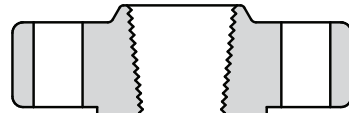

THREADED

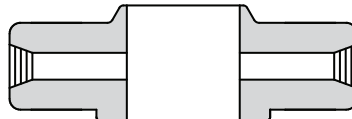
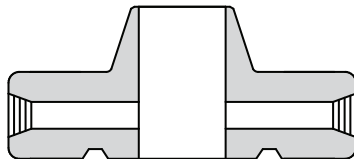

ORIFICE UNIONS WITH PLATES

www.SpecialtyFlange.com

Copyright © 2006 Specialty Flange & Fitting, Inc. All Rights Reserved. • Phone: (856) 728-8530 • Fax: (856) 728-1304
649 Lebanon Avenue, Williamstown, NJ, 08094 • Email: sales@SpecialtyFlange.com

CLASS 150#

ANSI B16.5 • Standard Forged Flanges

Dimensional Data

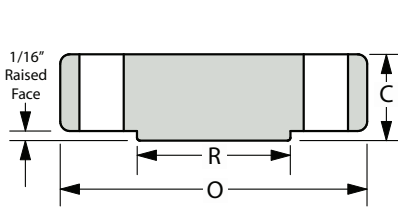

BLIND (BL)

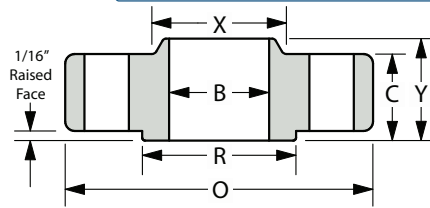

SLIP-ON (SO)

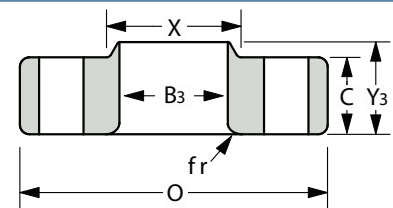

LAP JOINT (L J)

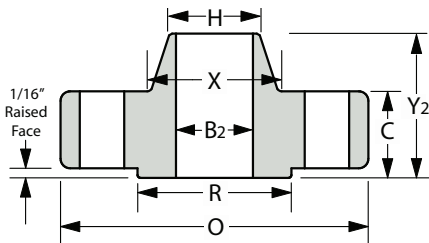

WELD NECK (WN)

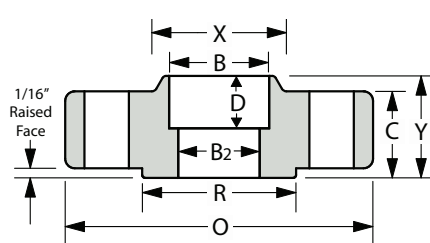

SOCKET WELD (SW)

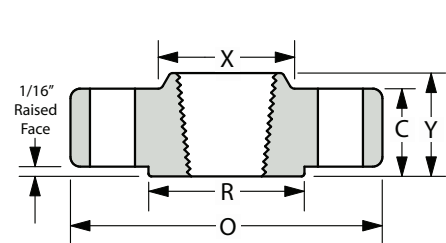

THREADED (TH)

Nominal Pipe Size	O (Outside Diameter)	R (Raised Face)	X (Hub Dia.)	C (General Thickness)	Y (Overall Length)	Y2	Y3	B (Inside Diameter)	B2	B3	fr (fillet radius)	D	H (Dia. bevel hub)	# of Holes - Diameter	Bolt Circle Dia.
1/2"	3.50	1.38	1.19	0.44	0.62	1.88	0.62	0.88	This dimension is determined by the pipe schedule and its corresponding inside diameter.	0.90	0.12	0.38	0.84	4 - 0.62	2.38
3/4"	3.88	1.69	1.50	0.50	0.62	2.06	0.62	1.09		1.11	0.12	0.44	1.05	4 - 0.62	2.75
1"	4.25	2.00	1.94	0.56	0.69	2.19	0.69	1.36		1.38	0.12	0.50	1.32	4 - 0.62	3.12
1-1/4"	4.62	2.50	2.31	0.62	0.81	2.25	0.81	1.70		1.72	0.19	0.56	1.66	4 - 0.62	3.50
1-1/2"	5.00	2.88	2.56	0.68	0.88	2.44	0.88	1.95		1.97	0.25	0.62	1.90	4 - 0.62	3.88
2"	6.00	3.62	3.06	0.75	1.00	2.50	1.00	2.44		2.46	0.31	0.69	2.38	4 - 0.75	4.75
2-1/2"	7.00	4.12	3.56	0.88	1.12	2.75	1.12	2.94		2.97	0.31	0.75	2.88	4 - 0.75	5.50
3"	7.50	5.00	4.25	0.94	1.19	2.75	1.19	3.57		3.60	0.38	0.81	3.50	4 - 0.75	6.00
3-1/2"	8.50	5.50	4.81	0.94	1.25	2.81	1.25	4.07		4.10	0.38	0.88	4.00	8 - 0.75	7.00
4"	9.00	6.19	5.31	0.94	1.31	3.00	1.31	4.57		4.60	0.44	0.94	4.50	8 - 0.75	7.50
5"	10.00	7.31	6.44	0.94	1.44	3.50	1.44	5.66		5.69	0.44	0.94	5.56	8 - 0.88	8.50
6"	11.00	8.50	7.56	1.00	1.56	3.50	1.56	6.72		6.75	0.50	1.06	6.63	8 - 0.88	9.50
8"	13.50	10.62	9.69	1.12	1.75	4.00	1.75	8.72		8.75	0.50	1.25	8.63	8 - 0.88	11.75
10"	16.00	12.75	12.00	1.19	1.94	4.00	1.94	10.88		10.92	0.50	1.31	10.75	12 - 1.00	14.25
12"	19.00	15.00	14.38	1.25	2.19	4.50	2.19	12.88		12.92	0.50	1.56	12.75	12 - 1.00	17.00
14"	21.00	16.25	15.75	1.38	2.25	5.00	3.12	14.14		14.18	0.50	1.63	14.00	12 - 1.12	18.75
16"	23.50	18.50	18.00	1.44	2.50	5.00	3.44	16.16		16.19	0.50	1.75	16.00	16 - 1.12	21.25
18"	25.00	21.00	19.88	1.56	2.69	5.50	3.81	18.18		18.20	0.50	1.94	18.00	16 - 1.25	22.75
20"	27.50	23.00	22.00	1.69	2.88	5.69	4.06	20.20		20.25	0.50	2.13	20.00	20 - 1.25	25.00
22"	29.50	25.25	24.25	1.81	3.13	5.88	4.25	22.22		22.25	0.50	2.38	22.00	20 - 1.38	27.25
24"	32.00	27.25	26.12	1.88	3.25	6.00	4.38	24.25		24.25	0.50	2.50	24.00	20 - 1.38	29.50

1. The C and Y dimensions include the 1/16" raised face for the 150# and 300# weight classes.

2. Tolerances are standard as per ANSI B 16.5

3. The Y3 dimension is the length for a "true" lap joint, however, it is usually accepted to make these to a standard slip-on length.

4. All shown dimensions are in inches. 5. Bolts 1/8" smaller than hole dia.

CLASS 300#

ANSI B16.5 • Standard Forged Flanges Dimensional Data

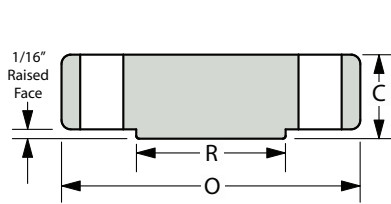

BLIND (BL)

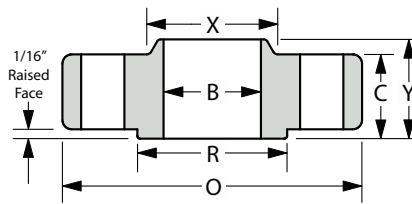

SLIP-ON (SO)

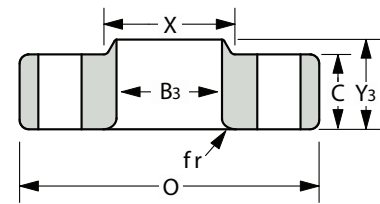

LAP JOINT (L J)

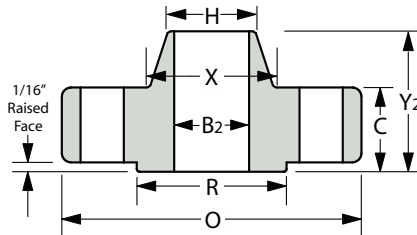

WELD NECK (WN)

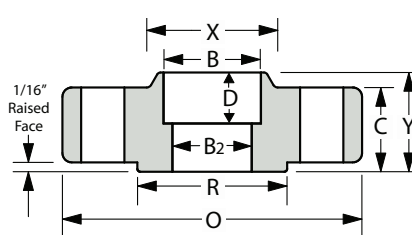

SOCKET WELD (SW)

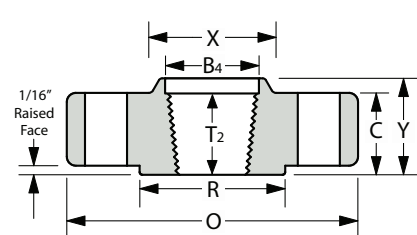

THREADED (TH)

Nom. Pipe Size	O (Outside Diameter)	R (Raised Face)	X (Hub Dia.)	C	T2 (Min. Thread Length)	Y (Overall Length)	Y2	Y3	B (Inside Dia.)	B2	B3	B4	fr	D	H (bevel hub)	# of Holes - Diameter	Bolt Circle Dia.
1/2"	3.75	1.38	1.50	0.56	0.62	0.88	2.06	0.88	0.88		0.90	0.93	0.12	0.38	0.84	4-0.62	2.62
3/4"	4.62	1.69	1.88	0.62	0.62	1.00	2.25	1.00	1.09	This dimension is determined by the pipe schedule and its corresponding inside diameter.	1.11	1.14	0.12	0.44	1.05	4-0.75	3.25
1"	4.88	2.00	2.12	0.69	0.69	1.06	2.44	1.06	1.36		1.38	1.41	0.12	0.50	1.32	4-0.75	3.50
1-1/4	5.25	2.50	2.50	0.75	0.81	1.06	2.56	1.06	1.70		1.72	1.75	0.19	0.56	1.66	4-0.75	3.88
1-1/2	6.12	2.88	2.75	0.81	0.88	1.19	2.69	1.19	1.95		1.97	1.99	0.25	0.62	1.90	4-0.88	4.50
2	6.50	3.62	3.31	0.88	1.12	1.31	2.75	1.31	2.44		2.46	2.50	0.31	0.69	2.38	8-0.75	5.00
2-1/2	7.50	4.12	3.94	1.00	1.25	1.50	3.00	1.50	2.94		2.97	3.00	0.31	0.75	2.88	8-0.88	5.88
3"	8.25	5.00	4.62	1.12	1.25	1.69	3.12	1.69	3.57		3.60	3.63	0.38	0.81	3.50	8-0.88	6.62
3-1/2	9.00	5.50	5.25	1.19	1.44	1.75	3.19	1.75	4.07		4.10	4.13	0.38	*No ASME data past 3" for this dimension	4.00	8-0.88	7.25
4"	10.00	6.19	5.75	1.25	1.44	1.88	3.38	1.88	4.57		4.60	4.63	0.44		4.50	8-0.88	7.88
5"	11.00	7.31	7.00	1.38	1.69	2.00	3.88	2.00	5.66		5.69	5.69	0.44		5.56	8-0.88	9.25
6"	12.50	8.50	8.12	1.44	1.81	2.06	3.88	2.06	6.72		6.75	6.75	0.50		6.63	12-0.88	10.62
8"	15.00	10.62	10.25	1.62	2.00	2.44	4.38	2.44	8.72		8.75	8.75	0.50		8.63	12-1.00	13.00
10"	17.50	12.75	12.62	1.88	2.19	2.62	4.62	3.75	10.88		10.92	10.92	0.50		10.75	16-1.12	15.25
12"	20.50	15.00	14.75	2.00	2.38	2.88	5.12	4.00	12.88		12.92	12.92	0.50		12.75	16-1.25	17.75
14"	23.00	16.25	16.75	2.12	2.50	3.00	5.62	4.38	14.14		14.18	14.18	0.50		14.00	20-1.25	20.25
16"	25.50	18.50	19.00	2.25	2.69	3.25	5.75	4.75	16.16		16.19	16.19	0.50	16.00	20-1.38	22.50	
18"	28.00	21.00	21.00	2.38	2.75	3.50	6.25	5.12	18.18		18.20	18.19	0.50	18.00	24-1.38	24.75	
20"	30.50	23.00	23.12	2.50	2.88	3.75	6.38	5.50	20.20		20.25	20.19	0.50	20.00	24-1.38	27.00	
22"	33.00	25.25	25.25	2.63	3.13	4.00	6.50	5.75	22.22		22.25	22.19	0.50	22.00	24-1.63	29.25	
24"	36.00	27.25	27.62	2.75	3.25	4.19	6.62	6.00	24.25		24.25	24.19	0.50	24.00	24-1.62	32.00	

1. The C and Y dimensions include the 1/16" raised face for the 150# and 300# weight classes.
 2. Tolerances are standard as per ANSI B 16.5

3. The Y3 dimension is the length for a "true" lap joint, however, it is usually accepted to make these to a standard slip-on length.
 4. All shown dimensions are in inches. 5. Bolts 1/8" smaller than hole dia.

CLASS 600#

ANSI B16.5 • Standard Forged Flanges Dimensional Data

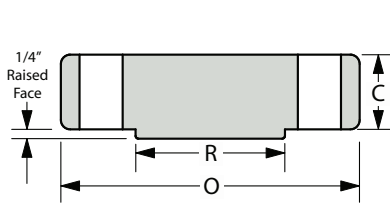

BLIND (BL)

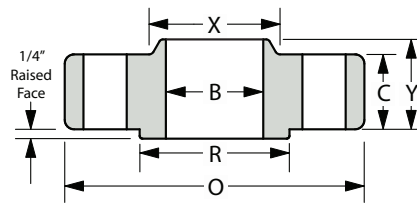

SLIP-ON (SO)

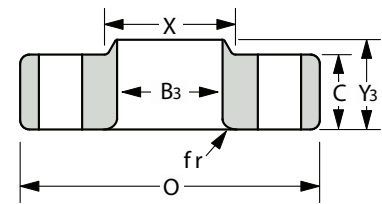

LAP JOINT (LJ)

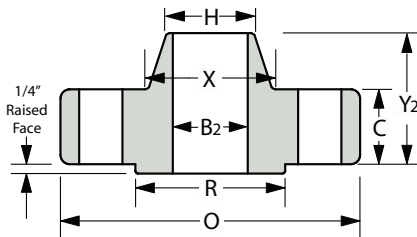

WELD NECK (WN)

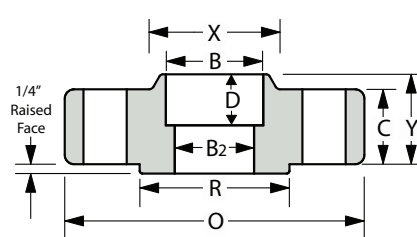

SOCKET WELD (SW)

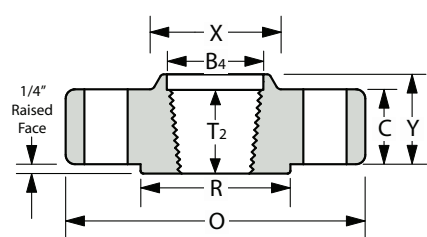

THREADED (TH)

Nom. Pipe Size	O (Outside Diameter)	R (Raised Face)	X (Hub Dia.)	C	T2 (Min. Thread Length)	Y (Overall Length)	Y2	Y3	B (Inside Dia.)	B2	B3	B4	fr	D	H (bevel hub)	# of Holes - Diameter	Bolt Circle Dia.
1/2"	3.75	1.38	1.50	0.56	0.62	0.88	2.06	0.88	0.88		0.90	0.93	0.12	0.38	0.84	4-0.62	2.62
3/4"	4.62	1.69	1.88	0.62	0.62	1.00	2.25	1.00	1.09	This dimension is determined by the pipe schedule and its corresponding inside diameter.	1.11	1.14	0.12	0.44	1.05	4-0.75	3.25
1"	4.88	2.00	2.12	0.69	0.69	1.06	2.44	1.06	1.36		1.38	1.41	0.12	0.50	1.32	4-0.75	3.50
1-1/4	5.25	2.50	2.50	0.81	0.81	1.12	2.62	1.12	1.70		1.72	1.75	0.19	0.56	1.66	4-0.75	3.88
1-1/2	6.12	2.88	2.75	0.88	0.88	1.25	2.75	1.25	1.95		1.97	1.99	0.25	0.62	1.90	4-0.88	4.50
2	6.50	3.62	3.31	1.00	1.12	1.44	2.88	1.44	2.44		2.46	2.50	0.31	0.69	2.38	8-0.75	5.00
2-1/2	7.50	4.12	3.94	1.12	1.25	1.62	3.12	1.62	2.94		2.97	3.00	0.31	0.75	2.88	8-0.88	5.88
3"	8.25	5.00	4.62	1.25	1.38	1.81	3.25	1.81	3.57		3.60	3.63	0.38	0.81	3.50	8-0.88	6.62
3-1/2	9.00	5.50	5.25	1.38	1.56	1.94	3.38	1.94	4.07		4.10	4.13	0.38	*No ASME data past 3" for this dimension	4.00	8-1.00	7.25
4"	10.75	6.19	6.00	1.50	1.62	2.12	4.00	2.12	4.57		4.60	4.63	0.44		4.50	8-1.00	8.50
5"	13.00	7.31	7.44	1.75	1.88	2.38	4.50	2.38	5.66		5.69	5.69	0.44		5.56	8-1.12	10.50
6"	14.00	8.50	8.75	1.88	2.00	2.62	4.62	2.62	6.72		6.75	6.75	0.50		6.63	12-1.12	11.50
8"	16.50	10.62	10.75	2.19	2.25	3.00	5.25	3.00	8.72		8.75	8.75	0.50		8.63	12-1.25	13.75
10"	20.00	12.75	13.50	2.50	2.56	3.38	6.00	4.38	10.88		10.92	10.88	0.50		10.75	16-1.38	17.00
12"	22.00	15.00	15.75	2.62	2.75	3.62	6.12	4.62	12.88		12.92	12.94	0.50		12.75	20-1.38	19.25
14"	23.75	16.25	17.00	2.75	2.88	3.69	6.50	5.00	14.14		14.18	14.19	0.50		14.00	20-1.50	20.75
16"	27.00	18.50	19.50	3.00	3.06	4.19	7.00	5.50	16.16		16.19	18.19	0.50	16.00	20-1.62	23.75	
18"	29.25	21.00	21.50	3.25	3.12	4.62	7.25	6.00	18.18			18.20	18.10	0.50	18.00	20-1.75	25.75
20"	32.00	23.00	24.00	3.50	3.25	5.00	7.50	6.50	20.20			20.25	20.19	0.50	20.00	24-1.75	28.50
22"	34.25	25.25	26.25	3.75	---	5.25	7.75	6.88	22.22		22.25	---	0.50	22.00	24-1.75	30.63	
24"	37.00	27.25	28.25	4.00	3.62	5.50	8.00	7.25	24.25		24.25	24.19	0.50	24.00	24-2.00	33.00	

1. The C and Y dimensions do not include the 1/4" raised face for the 600# and above weight classes.
 2. Tolerances are standard as per ANSI B 16.5

3. The Y3 dimension is the length for a "true" lap joint, however, it is usually accepted to make these to a standard slip-on length.
 4. All shown dimensions are in inches. 5. Bolts 1/8" smaller than hole dia.

CLASS 900#

ANSI B16.5 • Standard Forged Flanges Dimensional Data

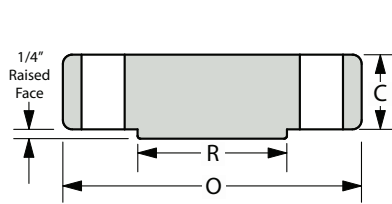

BLIND (BL)

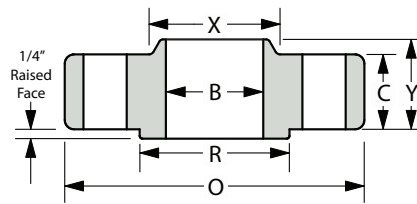

SLIP-ON (SO)

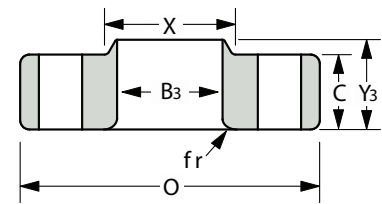

LAP JOINT (L J)

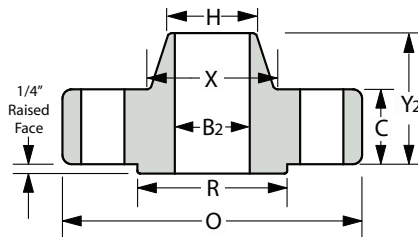

WELD NECK (WN)

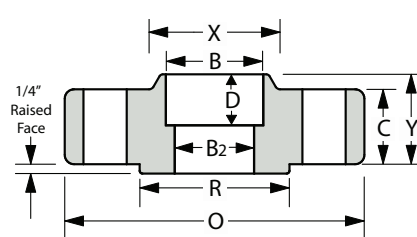

SOCKET WELD (SW)

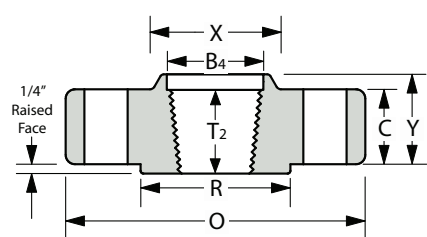

THREADED (TH)

Nom. Pipe Size	O (Outside Diameter)	R (Raised Face)	X (Hub Dia.)	C	T2 (Min. Thread Length)	Y (Overall Length)	Y2	Y3	B (Inside Dia.)	B2	B3	B4	fr	D	H (bevel hub)	# of Holes - Diameter	Bolt Circle Dia.
1/2"	4.75	1.38	1.50	0.88	0.88	1.25	2.38	1.25	0.88	This dimension is determined by the pipe schedule and its corresponding inside diameter.	0.90	0.93	0.13	0.38	0.84	4-0.88	3.25
3/4"	5.13	1.69	1.75	1.00	1.00	1.38	2.75	1.38	1.09		1.11	1.14	0.13	0.44	1.05	4-0.88	3.50
1"	5.88	2.00	2.06	1.13	1.13	1.63	2.88	1.63	1.36		1.38	1.41	0.13	0.50	1.32	4-1.00	4.00
1-1/4	6.25	2.50	2.50	1.13	1.19	1.63	2.88	1.63	1.70		1.72	1.75	0.19	0.56	1.66	4-1.00	4.38
1-1/2	7.00	2.88	2.75	1.25	1.25	1.75	3.25	1.75	1.95		1.97	1.99	0.25	0.63	1.90	4-1.13	4.88
2	8.50	3.62	4.13	1.50	1.50	2.25	4.00	2.25	2.44		2.46	2.50	0.31	0.69	2.38	8-1.00	6.50
2-1/2	9.63	4.12	4.88	1.63	1.88	2.50	4.13	2.50	2.94		2.97	3.00	0.31	0.75	2.88	8-1.13	7.50
3"	9.50	5.00	5.00	1.50	1.63	2.13	4.00	2.13	3.57		3.60	3.63	0.38	*	3.50	8-1.00	7.50
4"	11.50	6.19	6.25	1.75	1.88	2.75	4.50	2.75	4.57		4.60	4.63	0.44	*	4.50	8-1.25	9.25
5"	13.75	7.31	7.50	2.00	2.13	3.13	5.00	3.13	5.66		5.69	5.69	0.44	*	5.56	8-1.38	11.00
6"	15.00	8.50	9.25	2.19	2.25	3.38	5.50	3.38	6.72		6.75	6.75	0.50	*	6.63	12-1.25	12.50
8"	18.50	10.62	11.75	2.50	2.50	4.00	6.38	4.50	8.72		8.75	8.75	0.50	*	8.63	12-1.50	15.50
10"	21.50	12.75	14.50	2.75	2.81	4.25	7.25	5.00	10.88		10.92	10.92	0.50	*	10.75	16-1.50	18.50
12"	24.00	15.00	16.50	3.13	3.00	4.63	7.88	5.63	12.88		12.92	12.92	0.50	*	12.75	20-1.50	21.00
14"	25.25	16.25	17.75	3.38	3.25	5.13	8.38	6.13	*		14.18	14.18	0.50	*	14.00	20-1.63	22.00
16"	27.75	18.50	20.00	3.50	3.38	5.25	8.50	6.50	*		16.19	16.19	0.50	*	16.00	20-1.75	24.25
18"	31.00	21.00	22.25	4.00	3.50	6.00	9.00	7.50	*	18.20	18.19	0.50	*	18.00	20-2.00	27.00	
20"	33.75	23.00	24.50	4.25	3.63	6.25	9.75	8.25	*	20.25	20.19	0.50	*	20.00	20-2.13	29.50	
24"	41.00	27.25	29.50	5.50	4.00	8.00	11.50	10.50	*	24.25	24.19	0.50	*	24.00	20-2.63	33.50	

1. The C and Y dimensions do not include the 1/4" raised face for the 600# and above weight classes.

2. Tolerances are standard as per ANSI B 16.5

3. The Y3 dimension is the length for a "true" lap joint, however, it is usually accepted to make these to a standard slip-on length.

4. All shown dimensions are in inches.

5. Bolts 1/8" smaller than hole dia. Columns marked * have no corresponding value in ASME code, therefore, have been left blank.

CLASS 1500#

ANSI B16.5 • Standard Forged Flanges Dimensional Data

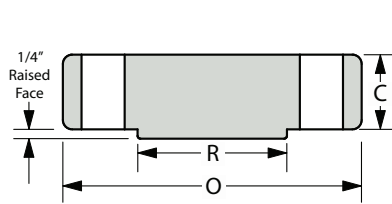

BLIND (BL)

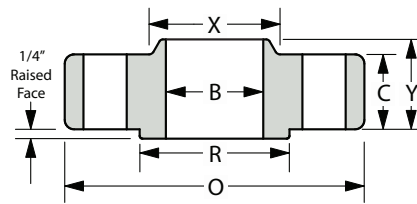

SLIP-ON (SO)

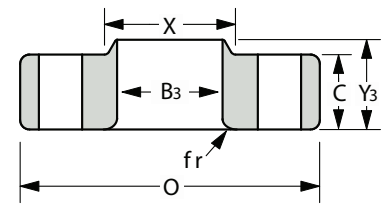

LAP JOINT (LJ)

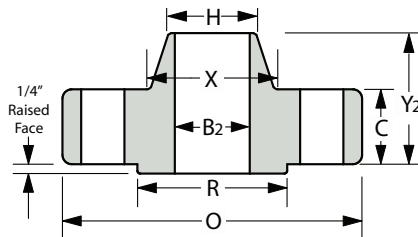

WELD NECK (WN)

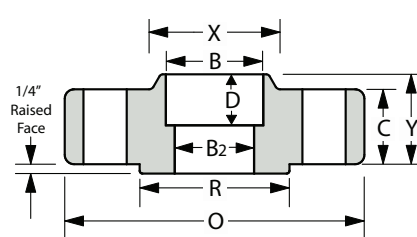

SOCKET WELD (SW)

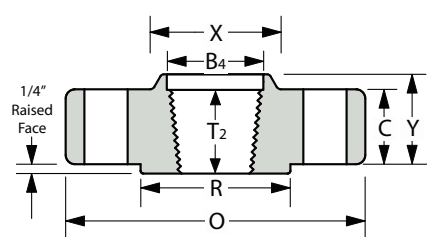

THREADED (TH)

Nom. Pipe Size	O (Outside Diameter)	R (Raised Face)	X (Hub Dia.)	C	T2 (Min. Thread Length)	Y (Overall Length)	Y2	Y3	B (Inside Dia.)	B2	B3	B4	fr	D	H (bevel hub)	# of Holes - Diameter	Bolt Circle Dia.
1/2"	4.75	1.38	1.50	0.88	0.88	1.25	2.38	1.25	0.88	This dimension is determined by the pipe schedule and its corresponding inside diameter.	0.90	0.93	0.13	0.38	0.84	4-0.88	3.25
3/4"	5.13	1.69	1.75	1.00	1.00	1.38	2.75	1.38	1.09		1.11	1.14	0.13	0.44	1.05	4-0.88	3.50
1"	5.88	2.00	2.06	1.13	1.13	1.63	2.88	1.63	1.36		1.38	1.41	0.13	0.50	1.32	4-1.00	4.00
1-1/4	6.25	2.50	2.50	1.13	1.19	1.63	2.88	1.63	1.70		1.72	1.75	0.19	0.56	1.66	4-1.00	4.38
1-1/2	7.00	2.88	2.75	1.25	1.25	1.75	3.25	1.75	1.95		1.97	1.99	0.25	0.63	1.90	4-1.13	4.88
2	8.50	3.62	4.13	1.50	1.50	2.25	4.00	2.25	2.44		2.46	2.50	0.31	0.69	2.38	8-1.00	6.50
2-1/2	9.63	4.12	4.88	1.63	1.88	2.50	4.13	2.50	2.94		2.97	3.00	0.31	0.75	2.88	8-1.13	7.50
3"	10.50	5.00	5.25	1.88	2.00	2.88	4.63	2.88	3.57		3.60	3.63	0.38	*	3.50	8-1.25	8.00
4"	12.25	6.19	6.38	2.13	2.25	3.56	4.88	3.56	4.57		4.60	4.63	0.44	*	4.50	8-1.38	9.50
5"	14.75	7.31	7.75	2.88	2.50	4.13	6.13	4.13	5.66		5.69	5.69	0.44	*	5.56	8-1.63	11.50
6"	15.50	8.50	9.00	3.25	2.75	4.69	6.75	4.69	6.72		6.75	6.75	0.50	*	6.63	12-1.50	12.50
8"	19.00	10.62	11.50	3.63	3.00	5.63	8.38	5.63	8.72		8.75	8.75	0.50	*	8.63	12-1.75	15.50
10"	23.00	12.75	14.50	4.25	3.31	6.25	10.00	7.00	10.88		10.92	10.92	0.50	*	10.75	12-2.00	19.00
12"	26.50	15.00	17.75	4.88	3.63	7.13	11.13	8.63	12.88		12.92	12.92	0.50	*	12.75	16-2.13	22.50
14"	29.50	16.25	19.50	5.25	*	*	11.75	9.50	*		14.18	14.18	0.50	*	14.00	16-2.38	25.00
16"	32.50	18.50	21.75	5.75	*	*	12.25	10.25	*		16.19	16.19	0.50	*	16.00	16-2.63	27.75
18"	36.00	21.00	23.50	6.38	*	*	12.88	10.88	*	18.20	18.19	0.50	*	18.00	16-2.88	30.50	
20"	38.75	23.00	25.25	7.00	*	*	14.00	11.50	*	20.25	20.19	0.50	*	20.00	16-3.13	32.75	
24"	46.00	27.25	30.00	8.00	*	*	16.00	13.00	*	24.25	24.19	0.50	*	24.00	16-3.63	39.00	

1. The C and Y dimensions do not include the 1/4" raised face for the 600# and above weight classes.

2. Tolerances are standard as per ANSI B 16.5

3. The Y3 dimension is the length for a "true" lap joint, however, it is usually accepted to make these to a standard slip-on length.

4. All shown dimensions are in inches. 5. Bolts 1/8" smaller than hole dia.

5. Columns marked * have no corresponding value in ASME code, therefore, have been left blank.

CLASS 2500#

ANSI B16.5 • Standard Forged Flanges

Dimensional Data

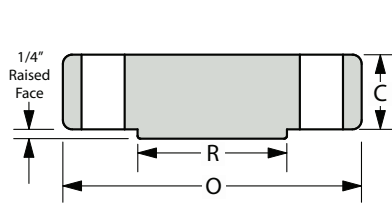

BLIND (BL)

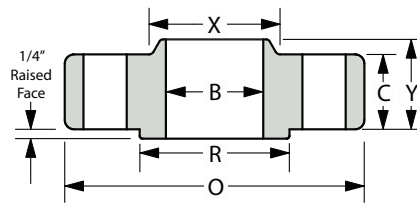

SLIP-ON (SO)

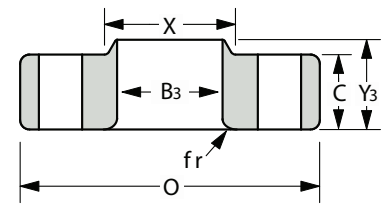

LAP JOINT (LJ)

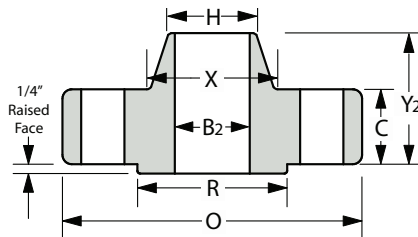

WELD NECK (WN)

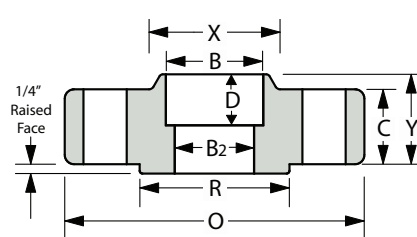

SOCKET WELD (SW)

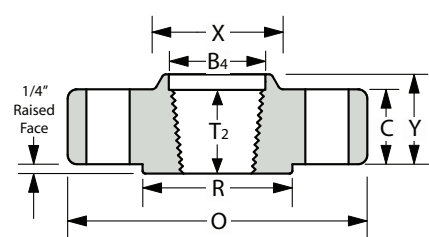

THREADED (TH)

Nom. Pipe Size	O (Outside Diameter)	R (Raised Face)	X (Hub Dia.)	C	T2 (Min. Thread Length)	Y (Overall Length)	Y2	Y3	B (Inside Dia.)	B2	B3	B4	fr	D	H (bevel hub)	# of Holes - Diameter	Bolt Circle Dia.
1/2"	5.25	1.38	1.69	1.19	1.13	1.56	2.88	1.56	0.88		0.90	0.93	0.13	0.38	0.84	4-0.88	3.50
3/4"	5.50	1.69	2.00	1.25	1.25	1.69	3.13	1.69	1.09		1.11	1.14	0.13	0.44	1.05	4-0.88	3.75
1"	6.25	2.00	2.25	1.38	1.38	1.88	3.50	1.88	1.36		1.38	1.41	0.13	0.50	1.32	4-1.00	4.25
1-1/4	7.25	2.50	2.88	1.50	1.50	2.06	3.75	2.06	1.70		1.72	1.75	0.18	0.56	1.66	4-1.13	5.13
1-1/2	8.00	2.88	3.13	1.75	1.75	2.38	4.38	2.38	1.95		1.97	1.99	0.25	0.63	1.90	4-1.25	5.75
2	9.25	3.62	3.75	2.00	2.00	2.75	5.00	2.75	2.44		2.46	2.50	0.31	0.69	2.38	8-1.13	6.75
2-1/2	10.50	4.12	4.50	2.25	2.25	3.13	5.63	3.13	2.94		2.97	3.00	0.31	0.75	2.88	8-1.25	7.75
3"	12.00	5.00	5.25	2.63	2.50	3.63	6.63	3.63	3.57		3.60	3.63	0.37	*	3.50	8-1.38	9.00
4"	14.00	6.19	6.50	3.00	2.75	4.25	7.50	4.25	4.57		4.60	4.63	0.44	*	4.50	8-1.63	10.75
5"	16.50	7.31	8.00	3.63	3.00	5.13	9.00	5.13	5.66		5.69	5.69	0.44	*	5.56	8-1.88	12.75
6"	19.00	8.50	9.25	4.25	3.25	6.00	10.75	6.00	6.72		6.75	6.75	0.50	*	6.63	8-2.13	14.50
8"	21.75	10.62	12.00	5.00	3.75	7.00	12.50	7.00	8.72		8.75	8.75	0.50	*	8.63	12-2.13	17.25
10"	26.50	12.75	14.75	6.50	4.25	9.00	16.50	9.00	10.88		10.92	10.92	0.50	*	10.75	12-2.63	21.25
12"	30.00	15.00	17.38	7.25	4.75	10.00	18.25	10.00	12.88		12.92	12.92	0.50	*	12.75	12-2.88	24.38

This dimension is determined by the pipe schedule and its corresponding inside diameter.

- The C and Y dimensions do not include the 1/4" raised face for the 600# and above weight classes.
- Tolerances are standard as per ANSI B 16.5
- The Y3 dimension is the length for a "true" lap joint, however, it is usually accepted to make these to a standard slip-on length.

- All shown dimensions are in inches.
- Bolts 1/8" smaller than hole dia.
- Columns marked * have no corresponding value in ASME code, therefore, have been left blank.
- ASME does not list the socket weld type flange as an option for 2500#.
- ASME Code limits dimensions to 12" Nominal Pipe Size.

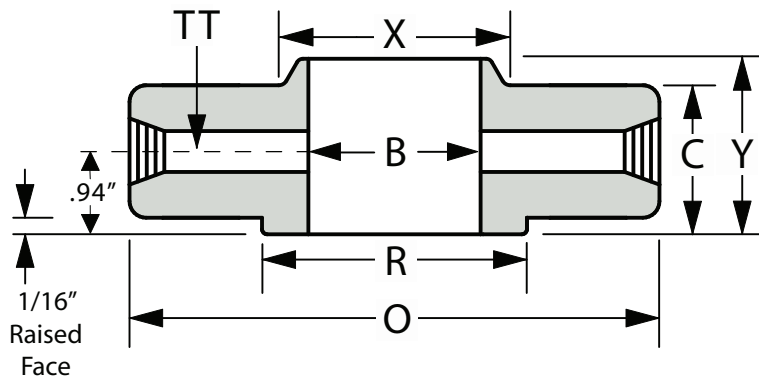

ORIFICE - SLIP-ON (OS)

Nom. Pipe Size	O (Outside Diameter)	R (Raised Face)	X (Hub Dia.)	C	TT (Dia. of pressure connection)	Y (Overall Length)	B (Inside Dia.)	# of Holes - Diameter	Dia. of Bolts	Bolt Circle Dia.
1"	4.88	2.00	2.12	1.50	0.25	1.88	1.36	4-0.69	.625	3.50
1-1/2"	6.12	2.88	2.75	1.50	0.25	1.88	1.95	4-0.81	.750	4.50
2"	6.50	3.62	3.31	1.50	0.25	1.94	2.44	8-0.69	.625	5.00
2-1/2"	7.50	4.12	3.94	1.50	0.25	2.00	2.94	8-0.81	.750	5.88
3"	8.25	5.00	4.62	1.50	0.375	2.06	3.57	8-0.81	.750	6.62
4"	10.00	6.19	5.75	1.50	0.50	2.12	4.57	8-0.81	.750	7.88
6"	12.50	8.50	8.12	1.50	0.50	2.12	6.72	12-0.88	.750	10.62
8"	15.00	10.62	10.25	1.62	0.50	2.44	8.72	12-1.00	.875	13.00
10"	17.50	12.75	12.62	1.88	0.50	2.62	10.88	16-1.12	1.000	15.25
12"	20.50	15.00	14.75	2.00	0.50	2.88	12.88	16-1.25	1.125	17.75
14"	23.00	16.25	16.75	2.12	0.50	3.00	14.14	20-1.25	1.125	20.25
16"	25.50	18.50	19.00	2.25	0.50	3.25	16.16	20-1.38	1.250	22.50
18"	28.00	21.00	21.00	2.38	0.50	3.50	18.18	24-1.38	1.250	24.75
20"	30.50	23.00	23.12	2.50	0.50	3.75	20.20	24-1.38	1.250	27.00
24"	36.00	27.25	27.62	2.75	0.50	4.19	24.25	24-1.62	1.500	32.00

- The C and Y dimensions include the 1/16" raised face.
- Tolerances are standard as per ANSI B 16.36
- All shown dimensions are in inches.
- Other sizes may be available per request.

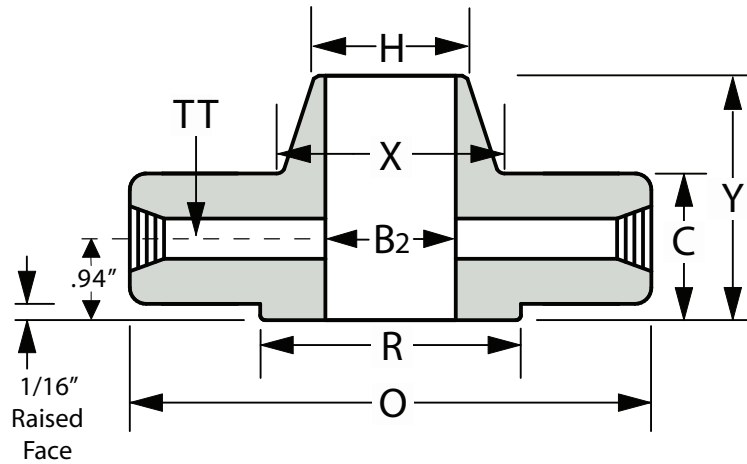

ORIFICE - WELD NECK (OW)

Nom. Pipe Size	O (Outside Diameter)	R (Raised Face)	X (Hub Dia.)	H (Bevel Hub Dia.)	C	TT (Dia. of pressure connection)	Y (Overall Length)	B2 (Inside Dia.)	# of Holes - Diameter	Dia. of Bolts	Bolt Circle Dia.
1"	4.88	2.00	2.12	1.32	1.50	0.25	3.25	This dimension is determined by the pipe schedule and its corresponding inside diameter.	4-0.69	.625	3.50
1-1/2"	6.12	2.88	2.75	1.90	1.50	0.25	3.38		4-0.81	.750	4.50
2"	6.50	3.62	3.31	2.38	1.50	0.25	3.38		8-0.69	.625	5.00
2-1/2"	7.50	4.12	3.94	2.88	1.50	0.25	3.50		8-0.81	.750	5.88
3"	8.25	5.00	4.62	3.50	1.50	0.375	3.50		8-0.81	.750	6.62
4"	10.00	6.19	5.75	4.50	1.50	0.50	3.62		8-0.81	.750	7.88
6"	12.50	8.50	8.12	6.63	1.50	0.50	3.94		12-0.88	.750	10.62
8"	15.00	10.62	10.25	8.63	1.62	0.50	4.38		12-1.00	.875	13.00
10"	17.50	12.75	12.62	10.75	1.88	0.50	4.62		16-1.12	1.000	15.25
12"	20.50	15.00	14.75	12.75	2.00	0.50	5.12		16-1.25	1.125	17.75
14"	23.00	16.25	16.75	14.00	2.12	0.50	5.62		20-1.25	1.125	20.25
16"	25.50	18.50	19.00	16.00	2.25	0.50	5.75		20-1.38	1.250	22.50
18"	28.00	21.00	21.00	18.00	2.38	0.50	6.25	24-1.38	1.250	24.75	
20"	30.50	23.00	23.12	20.00	2.50	0.50	6.38	24-1.38	1.250	27.00	
24"	36.00	27.25	27.62	24.00	2.75	0.50	6.62	24-1.62	1.500	32.00	

1. The C and Y dimensions include the 1/16" raised face.
2. Tolerances are standard as per ANSI B 16.36
3. All shown dimensions are in inches.

4. It is most standard to have an NPT of 1/2" in the side of the flange, however, other sizes may be available upon request.
5. Other nominal pipe sizes may be available per request.

CLASS 600#

ANSI B16.36 • Orifice Flanges Weld Neck Dimensional Data

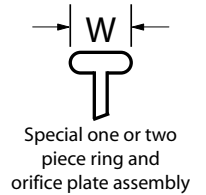
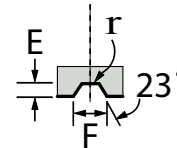
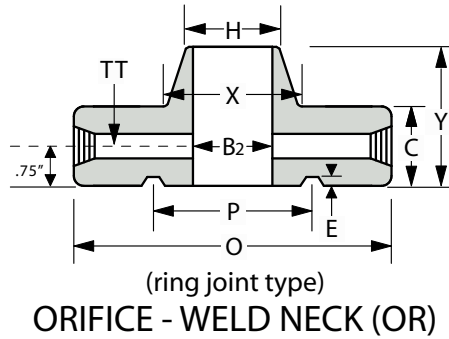
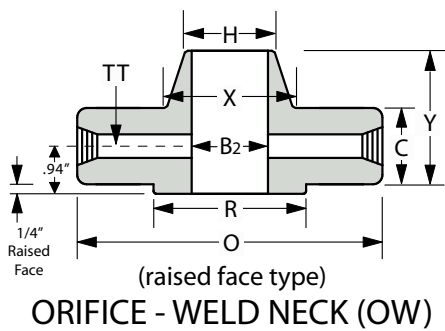

Nom. Pipe Size	O (Outside Diameter)	R (Raised Face)	X (Hub Dia.)	H (Bevel Hub Dia.)	C	TT (Dia. of pressure connection)	Y (Overall Length)	B2 (In-side Dia.)	Groove #	Groove Pitch Dia. P	Groove Depth E	Groove Width F	Radius At Bottom r	Special Oval W	# of Holes	Dia. of Holes		Dia. of Bolts	Bolt Circle Dia.								
																RF	RJ										
1"																											
1-1/2"	<div style="border: 1px solid black; padding: 5px; display: inline-block;"> ***Sizes 3" and smaller for the 600# Orifice class are dimensionally the same as 300# </div>																										
2"																											
2-1/2"																											
3"																											
4"	10.75	6.19	5.75	4.50	1.50	0.50	4.00		R37	5.875	0.312	0.469	0.03	1.06	8	1.00	1.00	.875	8.50								
6"	14.00	8.50	8.12	6.63	1.88	0.50	4.62		R45	8.312	0.312	0.469	0.03	1.06	12	1.12	1.12	1.000	11.50								
8"	16.50	10.62	10.25	8.63	2.19	0.50	5.25		R49	10.625	0.312	0.469	0.03	1.06	12	1.25	1.25	1.125	13.75								
10"	20.00	12.75	12.62	10.75	2.50	0.50	6.00		R53	12.750	0.312	0.469	0.03	1.06	16	1.38	1.38	1.250	17.00								
12"	22.00	15.00	14.75	12.75	2.62	0.50	6.12		R57	15.000	0.312	0.469	0.03	1.06	20	1.38	1.38	1.250	19.25								
14"	23.75	16.25	16.75	14.00	2.75	0.50	6.50		R61	16.500	0.312	0.469	0.03	1.06	20	1.50	1.50	1.375	20.75								
16"	27.00	18.50	19.00	16.00	3.00	0.50	7.00		R65	18.500	0.312	0.469	0.03	1.19	20	1.60	1.60	1.500	23.75								
18"	29.25	21.00	21.00	18.00	3.25	0.50	7.25		R69	21.000	0.312	0.469	0.03	1.19	20	1.75	1.75	1.625	25.75								
20"	32.00	23.00	23.12	20.00	3.50	0.50	7.50		R73	23.000	0.375	0.531	0.06	1.25	24	1.75	1.75	1.625	28.50								
24"	37.00	27.25	27.62	24.00	4.00	0.50	8.00								24	2.00	2.00	1.875	33.00								

This dimension is determined by the pipe schedule and its corresponding inside diameter.

- The C and Y dimensions do not include the 1/4" raised face.
- Tolerances are standard as per ANSI B 16.36
- All shown dimensions are in inches.
- It is most standard to have an NPT of 1/2" in the side of the flange, however, other sizes may be available upon request.
- Other nominal pipe sizes may be available per request.

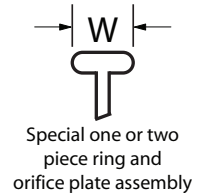
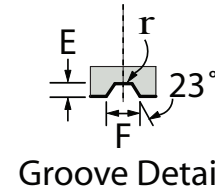
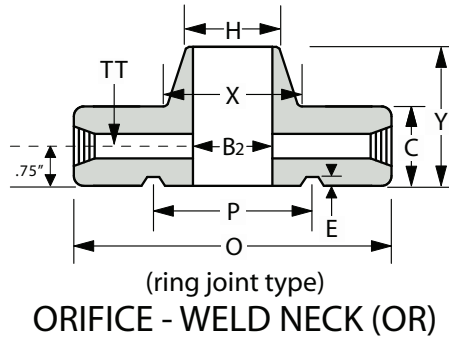
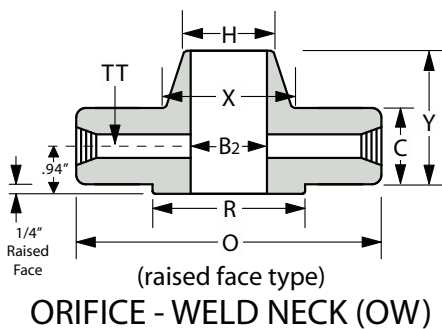

Nom. Pipe Size	O (Out-side Diameter)	R (Raised Face)	X (Hub Dia.)	H (Bevel Hub Dia.)	C	TT (Dia. of pressure connection)	Y (Overall Length)	B2 (In-side Dia.)	Groove #	Groove Pitch Dia. P	Groove Depth E	Groove Width F	Radius At Bottom r	Special Oval W	# of Holes	Dia. of Holes	Dia. of Bolts	Bolt Circle Dia.
1"	5.88	2.00	2.06	1.32	1.50	0.25	3.25	This dimension is determined by the pipe schedule and its corresponding inside diameter.	R16	2.000	0.250	0.344	0.03	1.00	4	1.00	.875	4.00
1-1/2"	7.00	2.88	2.75	1.90	1.50	0.25	3.50		R20	2.688	0.250	0.344	0.03	1.00	4	1.12	1.000	4.88
2"	8.50	3.62	4.12	2.38	1.50	0.25	4.00		R24	3.750	0.312	0.469	0.03	1.06	8	1.00	.875	6.50
2-1/2"	9.62	4.12	4.88	2.88	1.62	0.25	4.12		R27	4.250	0.312	0.469	0.03	1.06	8	1.12	1.000	7.50
3"	9.50	5.00	5.00	3.50	1.50	0.375	4.00		R31	4.875	0.312	0.469	0.03	1.06	8	1.00	.875	7.50
4"	11.50	6.19	6.25	4.50	1.75	0.50	4.50		R37	5.875	0.312	0.469	0.03	1.06	8	1.25	1.125	9.25
6"	15.00	8.50	9.25	6.63	2.19	0.50	5.50		R45	8.312	0.312	0.469	0.03	1.06	12	1.25	1.375	12.50
8"	18.50	10.62	11.75	8.63	2.50	0.50	6.38		R49	10.625	0.312	0.469	0.03	1.06	12	1.50	1.375	15.50
10"	21.50	12.75	14.50	10.75	2.75	0.50	7.25		R53	12.750	0.312	0.469	0.03	1.06	16	1.50	1.375	18.50
12"	24.00	15.00	16.50	12.75	3.12	0.50	7.88		R57	15.000	0.312	0.469	0.03	1.06	20	1.50	1.375	21.00
14"	25.25	16.25	17.75	14.00	3.38	0.50	8.38								20	1.62	1.500	22.00
16"	27.75	18.50	20.00	16.00	3.50	0.50	8.50								20	1.80	1.600	24.30
18"	31.00	21.00	22.25	18.00	4.00	0.50	9.00								20	2.00	1.875	27.00
20"	33.75	23.00	24.50	20.00	4.25	0.50	9.75								20	2.12	2.000	29.50
24"	41.00	27.25	29.50	24.00	5.50	0.50	11.50								20	2.62	2.500	35.50

1. The C and Y dimensions do not include the 1/4" raised face.
2. Tolerances are standard as per ANSI B 16.36.
3. All shown dimensions are in inches.
4. It is most standard to have an NPT of 1/2" in the side of the flange, however, other sizes may be available upon request.

5. Spaces left **blank** have no corresponding values as per ASME code. Usually this denotes a recommendation not to use this style at the corresponding size.
6. Other nominal pipe sizes may be available per request.

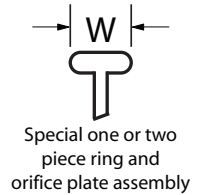
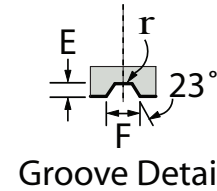
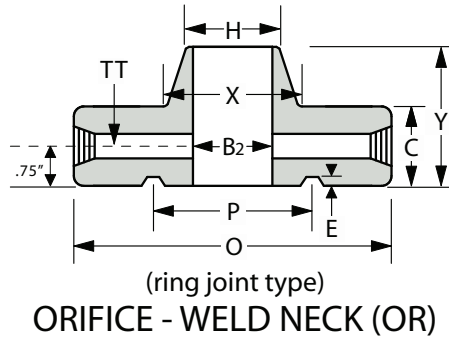
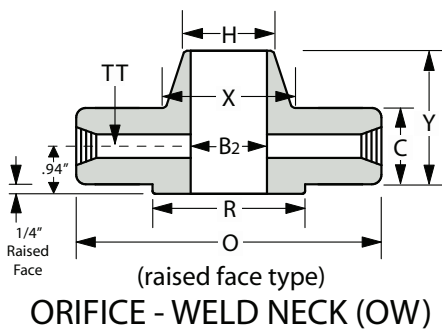

Nom. Pipe Size	O (Outside Diameter)	R (Raised Face)	X (Hub Dia.)	H (Bevel Hub Dia.)	C	TT (Dia. of pressure connection)	Y (Overall Length)	B2 (Inside Dia.)	Groove #	Groove Pitch Dia.	Groove Depth	Groove Width	Groove Radius At Bottom	Special Oval	# of Holes	Dia. of Holes	Dia. of Bolts	Bolt Circle Dia.
1"	5.88	2.00	2.06	1.32	1.50	0.25	3.25	This dimension is determined by the pipe schedule and its corresponding inside diameter.	R16	2.000	0.250	0.344	0.03	1.00	4	1.00	.875	4.00
1-1/2"	7.00	2.88	2.75	1.90	1.50	0.25	3.50		R20	2.688	0.250	0.344	0.03	1.00	4	1.12	1.000	4.88
2"	8.50	3.62	4.12	2.38	1.50	0.25	4.00		R24	3.750	0.312	0.469	0.03	1.06	8	1.00	.875	6.50
2-1/2"	9.62	4.12	4.88	2.88	1.62	0.25	4.12		R27	4.250	0.312	0.469	0.03	1.06	8	1.12	1.000	7.50
3"	10.50	5.00	5.25	3.50	1.88	0.375	4.62		R35	5.375	0.312	0.469	0.03	1.06	8	1.25	1.125	8.00
4"	12.25	6.19	6.38	4.50	2.12	0.50	4.88		R39	6.375	0.312	0.469	0.03	1.06	8	1.38	1.250	9.50
6"	15.50	8.50	9.00	6.63	3.25	0.50	6.75		R46	8.312	0.375	0.531	0.06	1.12	12	1.50	1.375	12.50
8"	19.00	10.62	11.50	8.63	3.62	0.50	8.38								12	1.75	1.625	15.50
10"	23.00	12.75	14.50	10.75	4.25	0.50	10.00								12	2.00	1.875	19.00
12"	26.50	15.00	17.75	12.75	4.88	0.50	11.12								16	2.12	2.000	22.50
14"	29.50	16.25	19.50	14.00	5.25	0.50	11.75								16	2.38	2.250	25.00
16"	32.50	18.50	21.75	16.00	5.75	0.50	12.25								16	2.60	2.500	27.80
18"	36.00	21.00	23.50	18.00	6.38	0.50	12.88								16	2.88	2.750	30.50
20"	38.75	23.00	25.25	20.00	7.00	0.50	14.00								16	3.12	3.000	32.75
24"	46.00	27.25	30.00	24.00	8.00	0.50	16.00								16	3.62	3.500	39.00

- The C and Y dimensions do not include the 1/4" raised face.
- Tolerances are standard as per ANSI B 16.36.
- All shown dimensions are in inches.
- It is most standard to have an NPT of 1/2" in the side of the flange, however, other sizes may be available upon request.

- Spaces left **blank** have no corresponding values as per ASME code. Usually this denotes a recommendation not to use this style at the corresponding size.
- Other nominal pipe sizes may be available per request.

CLASS 2500#

ANSI B16.36 • Orifice Flanges Weld Neck Dimensional Data

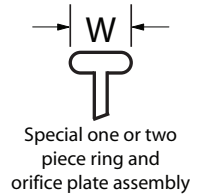
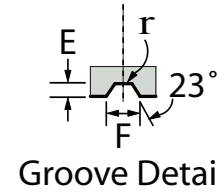
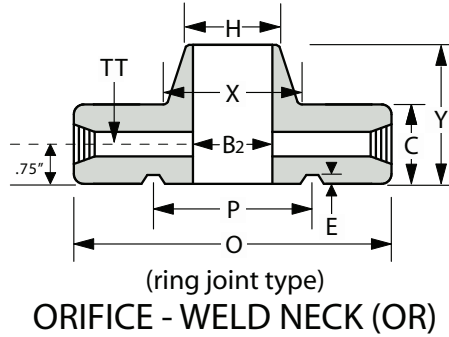
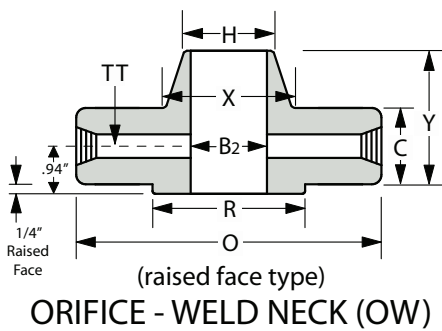

Nom. Pipe Size	O (Outside Diameter)	R (Raised Face)	X (Hub Dia.)	H (Bevel Hub Dia.)	C	TT (Dia. of pressure connection)	Y (Overall Length)	B2 (Inside Dia.)	Groove #	Groove Pitch Dia. P	Groove Depth E	Groove Width F	Radius At Bottom r	Special Oval W	# of Holes	Dia. of Holes	Dia. of Bolts	Bolt Circle Dia.	
1"	6.25	2.00	2.25	1.32	1.50	0.25	3.62	This dimension is determined by the pipe schedule and its corresponding inside diameter.	R18	2.375	0.250	0.344	0.03	1.00	4	1.00	.875	4.25	
1-1/2"	8.00	2.88	3.12	1.90	1.75	0.25	4.38		R23	3.250	0.312	0.469	0.03	1.06	4	1.25	1.125	5.75	
2"	9.25	3.62	3.75	2.38	2.00	0.25	5.00		R26	4.000	0.312	0.469	0.03	1.06	8	1.12	1.000	6.75	
2-1/2"	10.50	4.12	4.50	2.88	2.25	0.25	5.62		R28	4.375	0.375	0.531	0.06	1.19	8	1.25	1.125	7.75	
3"	12.00	5.00	5.25	3.50	2.62	0.375	6.62		R32	5.000	0.375	0.531	0.06	1.19	8	1.38	1.250	9.00	
4"	14.00	6.19	6.50	4.50	3.00	0.50	7.50								8	1.62	1.500	10.75	
6"	19.00	8.50	9.25	6.63	4.25	0.50	10.75								8	2.12	2.000	14.50	
8"	21.75	10.62	12.00	8.63	5.00	0.50	12.50								12	2.12	2.000	17.25	
10"	26.50	12.75	14.75	10.75	6.50	0.50	16.50								12	2.62	2.500	21.25	
12"	30.00	15.00	17.38	12.75	7.25	0.50	18.25								12	2.88	2.750	24.38	
14"																			
16"																			
18"																			
20"																			
24"																			

- The C and Y dimensions do not include the 1/4" raised face.
- Tolerances are standard as per ANSI B 16.36.
- All shown dimensions are in inches.
- It is most standard to have an NPT of 1/2" in the side of the flange, however, other sizes may be available upon request.
- Spaces left **blank** have no corresponding values as per ASME code. Usually this denotes a recommendation not to use this style at the corresponding size.
- Other nominal pipe sizes may be available per request.